

INSTRUCTIONS FOR USE



CE



SERVOSpin *SmartPro*

REF H7 680

INSTRUCTIONS FOR USE

 CAUTION!	To ensure the safety of the centrifuge, prevent the unit from being damaged by the following factors: Chemical effects, environmental influences, including direct sunlight, corrosion, abrasion and wear of nameplate and other safety components.
--	---

Foreword

Thank you for purchasing our SmartPro centrifuge. This Manual for users contains function and operation of the Instrument. In order to use the instrument properly, please read this manual carefully before using the Instrument.

Safety Tips

- * Please read this manual carefully for the first-time using!
- * SmartPro Centrifuge can only be operated by trained or authorized persons;
- * The maintenance of the instrument can only be done by servoprax or authorized dealers.
- * Please NEVER use the following materials in the centrifuge:
 - Inflammable and explosive materials;
 - Strengthen chemical materials;
 - Toxic or radioactive substances or pathogenic micro-organisms and so on.
- * Only qualified maintenance person using the appropriate tools can do operation on the system maintenance of SmartPro Centrifuge.
- * If encountered the cases not mentioned in the manual, please contact servoprax or authorized dealers to ask the right approach.
- * Use the accessories supplied by servoprax as far as possible. If you want to use other accessories, servoprax will not be responsible for the adverse consequences. However, users can submit an application to the servoprax to verify compliance with the servoprax equipment accessories requirements.
- * Inspections and maintenance of the SmartPro Centrifuge must be conducted at the specified time intervals.

Security Protections

- * Plug the power supply or switch power button with wet hand was strictly prohibited. Plug the power cable with power was strictly prohibited.
- * Maintain and scrub the machine with the power was strictly prohibited.
- * The sample over than tube volume 70% which the centrifugation was strictly prohibited.
- * Please check the rotor, reinsert and tighten it.!

Contents

	Page
1. Contents	13
2. Function, operating elements	13
3. Installation introduction	13
4. Performance parameters	14
5. Operation instruction	14– 16
6. Maintenance	16
7. Failure analysis and solution	17
8. Safety instructions	17

Appendix 1

Connection diagram	18
Packing list	19
Warranty card	19
Maintenance instructions, scope of warranty	19
Qualified certificate	20

1. Introduction

The SERVOspin SmartPro Centrifuge is a combination of design and manufacturing technology. The entire structure is compact, intuitively designed, smooth and space-saving. The device convinces with versatility and flexibility. The SERVOspin SmartPro Centrifuge is suitable for microporous tubular filters, faster centrifugation, microblood cell separation and microbial sample preparation. Before using the centrifuge for the first time, please read these instructions carefully and keep them handy at all times.

2. FUNCTION, APPEARANCE INTRODUCING

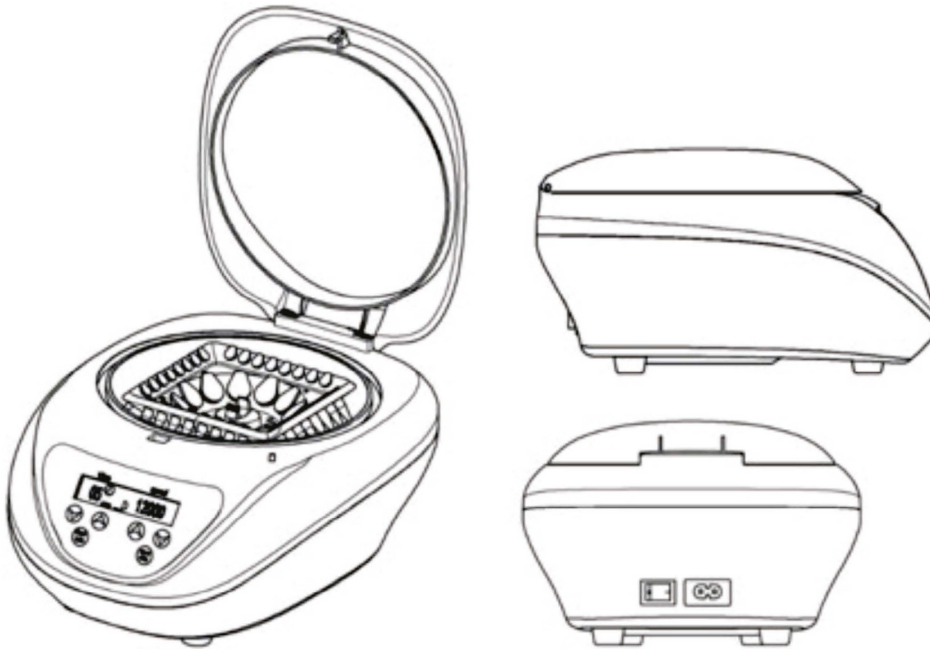

1. transparent lid.
2. upper base.
3. rotor.
4. control panel.
5. bottom base.
6. antislip foot pad.
7. lock
8. lid bar
9. power switch.
10. ac 110 - 230 V power plug

3. Installing the device

- 3.1 Place the centrifuge onto a level , horizontal surface. Make sure that the ventilation slits are not blocked.
- 3.2 Insert the column connector of the adapter to power connector of the device ,and insert another connector of the adapter to mains power supply 110 - 230 V~

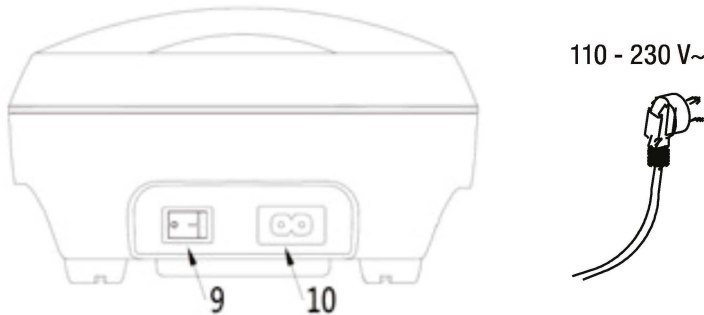

⚠ Caution

- * Check the appearance before operate the machine whether the plastic enclosure was damaged or not.
- * Press to open the transparent lid automatically, open easily without abnormal sound.
- * Check the transparent lid bar if have the loosing phenomenon .
- * Check the power cable and switch if connection is fixed ?

4. Technical data

Model	SERVOspin SmartPro
Power supply	110 - 230 V~ 50/60Hz
Power	45 W
Max. speed	Haematocrit rotor: 500 - 12000 rpm Standard rotor: 500 - 7000 rpm
Max. centrifugal force	9660 rcf
Motor	DC24V/DC PM Motor
Timer	1 – 99 min./1 – 59 sec.
Max. load	6/8 × 15/5 ml tubes
Max. permitted density	1.2 g/ml
Acceleration time to max. speed	≤12 s
Braking time from max. speed	≤16 s
Ambient temperature	5 °C ~ 40 °C/80 %
Dimensions (W x D x H)	194 mm × 229 m × 120 mm
Weight (with rotor)	2 kg

5. Operation

5.1 Operation elements

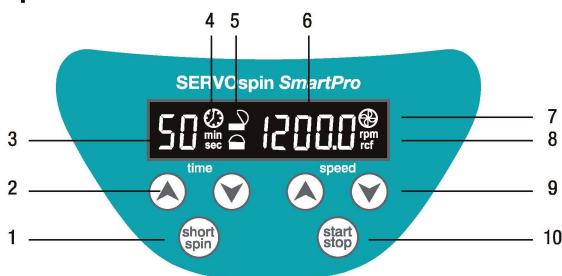

1. Short spin button
2. Time setting button (min./sec)
3. Timer display

4. Timer display (min./sec.)
5. Lid indication
6. Speed display button
7. Operation indication
8. RCF RPM indication
9. Speed setting button
10. Start / stop button

5.2 Opening / closing the lid

To open the lid:

The centrifuge lid will be open automatically once press the lid

Closing the lid:

Press centrifuge lid, it will be closed

5.3 Switch on / Switch off

As the picture showing Power button, tune on "I" means Power On.

Tune on "O" means Power Off.

5.4 Inserting / changing the rotor

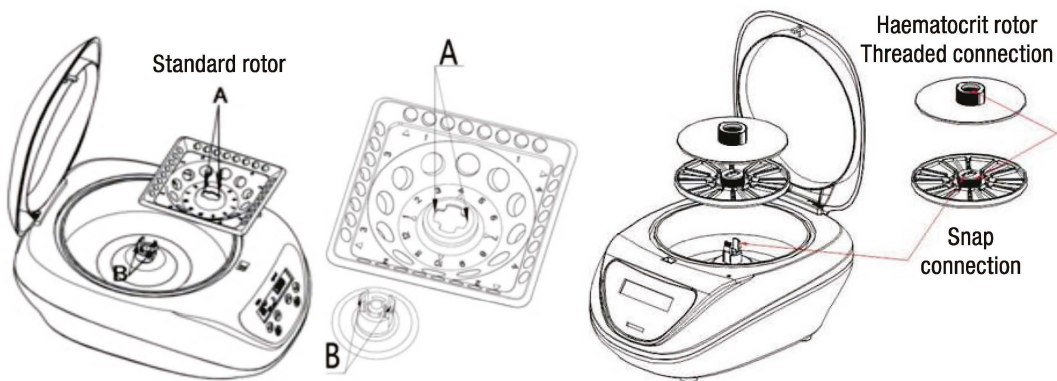

As the picture "A" "B" point showing and make sure the "A" "B" shape of positioning is same, both hands hold the rotor symmetrically then straight down moving, heard the "ka" means the rotor was locked completely.

Please note: all kinds of rotor which the loading way is same.

5.5 Disassembly of the rotor

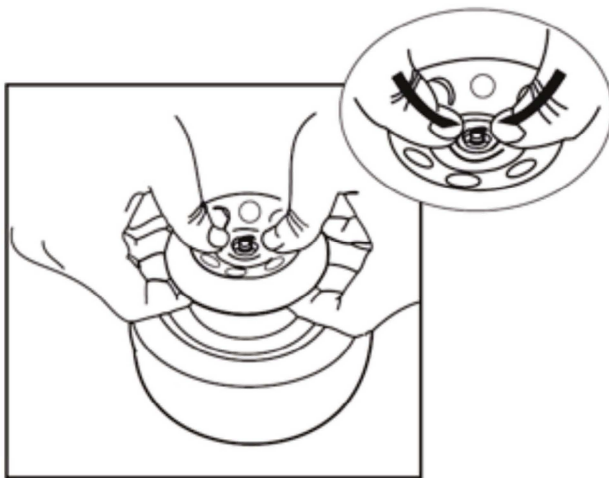

- ⚠ 1. Prohibit Pull out the rotor mandatory will damage the motor and rotor.
 2. The rotor which printing the digital No. Please keep this side with front side, it also will damage the rotor if installed backward.

The rotors are available as a spare part:

Haematocrit rotor: **REF H7 830-RO**

Standard rotor: **REF H7 830-QR**

5.6 Correct methods for placing the tube

12 tubes, 8 tubes, 6 tubes, 4 tubes, 2 tubes asymmetrical balance placed



5.7 Start /Stop machine

example application

Start machine

Open the transparent lid Loading the rotor ► placed tube with asymmetrical and balance ► Power on ► Closed the transparent lid

Example application: Set the speed at 12000 rpm for 10 mins operation

Press speed setting button to adjust the required speed 12000 rpm

Press timer setting button to adjust the required 10mins

Finish the settings as follows:



Press **start stop** to start machine, it will be according setting countdown stops.

A buzzer alarm indicates that the centrifugation is complete.

Press both of speed setting buttons hold for 3 seconds, RPM and RCF switched.

The machine will be stop operation when countdown finish.

Buzzer Alarm means finish the centrifuge this time .

⚠ The centrifuge stops after the entered running time has elapsed. If the rotor comes to a standstill, a signal tone sounds.

After a longer standstill, there may be a noise in the motor if it is started up again. The noise is caused by a slight vibration of the carbon brushes and disappears after approx. 2 - 3 minutes!

Stopping the centrifuge

Press key „Start/Stop“

Open the centrifuge lid ► remove the tubes ► switch off the centrifuge!

If you do not use the centrifuge again afterwards, close the lid!

6. Maintenance, cleaning and decontamination

- ⚠ The rotor and the outside of the centrifuge should be cleaned regularly with a damp cloth. Disconnect the centrifuge from the mains, remove the rotor and clean it separately. Only neutral, non-abrasive agents may be used for cleaning! Please check the rotor and especially the rotor bores regularly for deposits or damage, reinsert the rotor and tighten it!
- ⚠ Please check the rotor and especially the rotor bores regularly for deposits or damage, then reinsert the rotor and tight it.
- ⚠ If hazardous material has been spilled on or in the centrifuge, appropriate decontamination must be carried out.
- ⚠ The centrifuge can be disinfected with a cloth soaked in 70% alcohol. We recommend wipe disinfection e.g. with Meliseptol sensitive Wipes or bode Microbac Tissues.
- ⚠ Before using a cleaning or decontamination procedure other than that recommended by the manufacturer, check with the manufacturer that the intended procedure will not harm the centrifuge and accessories.
- ⚠ As a safety precaution, the centrifuge and accessories should be cleaned and decontaminated before maintenance, repair or transfer.

7. Error analysis and solution

Error	Cause	Solution
E01	1. Check the transparent lid is tightly covered, or if the lock is worn and the lid is not tight, it will automatically spring open. 2. The door cover switch is in poor contact.	1. Re-Connect the power, cover the lid 2. Contact the manufacturer
E02	1. The lid is opened during operation. 2. The lid switch is in poor contact	1. Power Off and waiting 1minute and restart. 2. Contact the manufacturer
E10	1. Motor damaged. 2. Motor test failure.	1. Power Off and waiting 1minute and restart. 2. Contact the manufacturer
Lid can't opened.	1. Check something was below the pressing plate. 2. Check the lid triangle button damaged or not.	1.Remove the foreign matter 2.Replace the transparent lid 3. Contact the manufacturer
Larger noise	1. Check the rotor if was tightly locked? 2. Check the loading if was symmetrical balance	1. .Fixed the rotor 2. Loading should be symmetrical balance placed 3. Contact the manufacturer
LCD window not lighting	1. No power	Re-Connect the power or contact the manufacturer

8. Safety precautions

- ⚠ Do not lean on the centrifuge!
- ⚠ Do not remain within the safety area (300 mm in each direction of the centrifuge) for longer than is necessary for operation!
- ⚠ Do not place any hazardous substances within the safety area!
- ⚠ The rotor and the rotor lid must always be securely fastened. If the centrifuge makes unusual noises when started , the rotor or rotor lid is not fastened correctly. Switch the device off immediately by pressing "START/STOP" button.
- ⚠ Do not use damaged rotors!
- ⚠ Do not move the centrifuge during the run!

- 8.1 Place the tubes
- 8.2 A liquid density of 1.2g/ml must not be exceeded at the max. speed!
- 8.3 Damaged tubes can not be centrifuged. This is because broken tubes can, in addition to sample loss, result in further damage to the centrifuge.
- 8.4 Close the test tube lids before centrifuging. Open lids can be ripped off during centrifuging and damage the centrifuge!
- 8.5 Must load the test tubes symmetrically!
- 8.6 Maintain of rotor!
- 8.6.1 Even slight scratches and tears of the rotor can lead to serious internal material damage!
- 8.6.2 Avoid damage caused by aggressive chemicals, including among others: strong and weak alkali, strong acids!
- 8.6.3 In the event of contamination caused by aggressive agents, The rotor must be cleaned immediately using a neutral cleaning liquid!

Annex 1 Wiring diagram for centrifuge

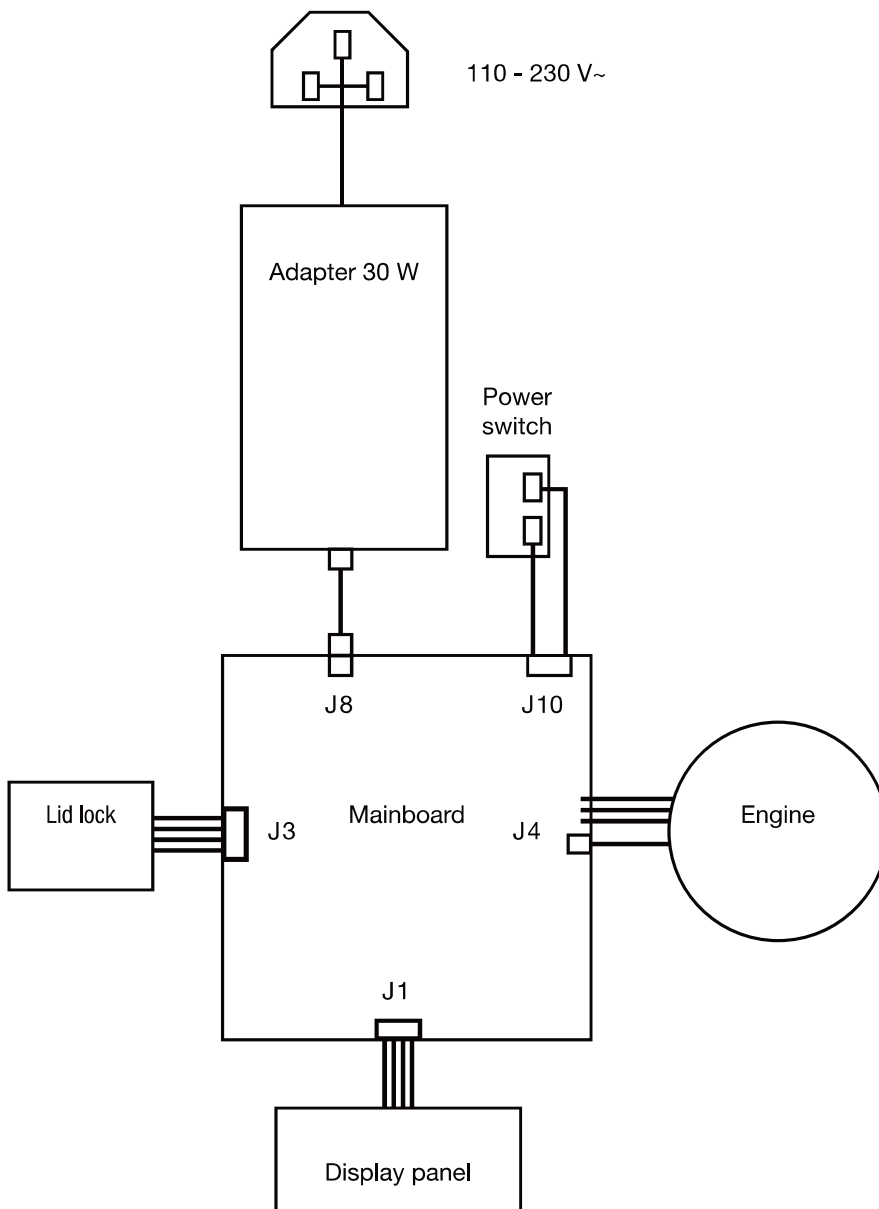

Packing List

No.	Item	Type	Quantity
1	Mini centrifuge	SERVOspin SmartPro	1
2	Rotor		3
3	Centrifuge tube adapter		1 Set
4	Rotor lid		1
5	Instructions for use		1

WARRANTYCARD

Dear customer:

Thank you very much for choose our Smartspin centrifuge .

Product	Table centrifuge
Name	SERVOspin SmartPro
Serial number	
Date of purchase	
Purchase company	
Purchase name	
Purchase address	
Customer	
Address	
Telephone number	
Fax number	
E-Mail	

WARRANTY

The warranty period is 18 months from the date of purchase. During this period, the manufacturer offers a free repair service. The warranty comes into force when a component needs to be replaced due to a quality defect. The warranty does not apply to damage caused by improper use, improper cleaning, fall, fire, thunderstorm, storm or force majeure! The costs for transport are not subject to the warranty!

SCOPE OF WARRANTY

The user must use and operate the centrifuge in accordance with the requirements of this instruction for use! Operation, installation, commissioning, modification, change of accessories, maintenance, etc. may only be performed by specialized or authorized personnel! Routine maintenance must be carried out regularly as specified in this instruction for use!

DISPOSAL OF THE PRODUCT IN ACCORDANCE WITH DIRECTIVE 2002/96/EC (WEEE)

- The product must NOT be disposed of together with household waste! Please hand in the device at a regional collection point authorised by the authorities or return it to your specialist dealer!
- Separate disposal of electrical equipment avoids possible negative impacts on the environment and human health and enables the targeted recycling of the materials used. This results in a significant saving of energy and resources. As a reminder of the obligation to dispose of electrical appliances separately, the product is marked with a crossed-out gauze bin (as shown below).

